

### Installation Instructions

**General Note:** This product is to be installed by a licensed plumber, installation must comply with AS/NZS 3500 and local plumbing codes.

#### Pressures & Temperatures

Maximum Hydrostatic Pressure — 500 kpa. (As per AS/NZS3500)

**Note: AS/NZS 3500.1-2003 (Clause 3.3.4) states that "Provision shall be made to ensure that the maximum static pressure at any outlet, other than a fire service outlet, within a building does not exceed 500 kPa.**

**Note: Pressures above 500kPa can cause damage from water hammer, reduced life of appliances, taps and fittings, and cause excessive noise in the system.**

Minimum Hydrostatic Pressure — 100 kpa

The Maximum operating temperature for the Mixer Tap is 65°C.

**Please ensure that the lines are flushed prior to installation as contaminates in the water can damage the Ceramic Cartridge, flow regulator and also affect the performance of the Mixer.**

1. Remove product from packaging and check for damages, if the product is damaged do not install and return to store of purchase.
2. The WELS compliant aerator has been pre-assembled into the mixer outlet. To comply with WELS the flow regulated aerator must remain in place.
3. Ensure Product is complete as per exploded drawing.
4. A single 35mm Hole is required in the mounting surface.
5. The maximum mounting surface thickness cannot exceed 37mm.
6. Ensuring bench sealing washer (A) is in place on the base of Mixer.
7. Firmly screw the Mixer tails (B) into base of the Mixer being careful to avoid damage to the o'ring seals, the Mixer tails are colour coded, Red for hot and Blue for cold, the mixer base inlet holes are stamped with 'H' for Hot and 'C' for cold.
8. Screw threaded rods (C) into base of Mixer.
9. Feed the Mixer tails through the Mounting surface, each end alternatively and position the mixer on the mounting surface ensuring the sealing washer (A) is positioned correctly.
10. Slide Stabiliser Bracket (E) and Rubber Horse Shoe (F) onto threaded rod (C) followed by Metal Horse shoe Plate (G).
11. **N.B The Mixer Tails should be positioned towards the user and the Fixing bolt to the back.**
12. Using Fixing Nut (H) tighten Mixer to mounting Surface.
13. Connect Mixer tails to Mains Water supply line.
14. Ensure the Mixer tails are not Kinked, Bent, stretched or twisted when assembling to the Mains Water Supply. The Mixer Tail connection between the mixer and the Water supply must have a natural curve.
15. Ensure Mixer tails are not exposed to Abrasions, corrosive agents or alike.
16. It is recommended that In-Line filters be installed to ensure a cleaner flow of water to the mixer.

#### To the consumer

1. The Mixer is to only be cleaned with warm soapy water.
2. **Under No Circumstances** should any abrasive, cream or acid based cleaning agents be used as these types of cleaners will damage the chrome finish, Cartridge, seals and aerators.

#### Warranty:

For continued piece of mind, this product comes with a limited warranty from date of purchase. For full warranty terms and conditions of the warranty including how to claim and your rights as a consumer, please consult [www.raymor.com.au](http://www.raymor.com.au) "If you are a consumer as defined under the Australian Consumer Law, our goods come with guarantees that cannot be excluded under the Australian Consumer Law. You are entitled to a replacement or refund for a major failure and compensation for any other reasonably foreseeable loss or damage. You are also entitled to have the goods repaired or replaced if the goods fail to be of acceptable quality and the failure does not amount to a major failure."

#### Warranty Contact Details:

Tradelink Pty Ltd  
 ABN: 2900003832  
 1051 Nudgee Rd  
 Banyo QLD 4014  
 Ph: 1300 658 277  
 Warranty@Tradelink.com.au

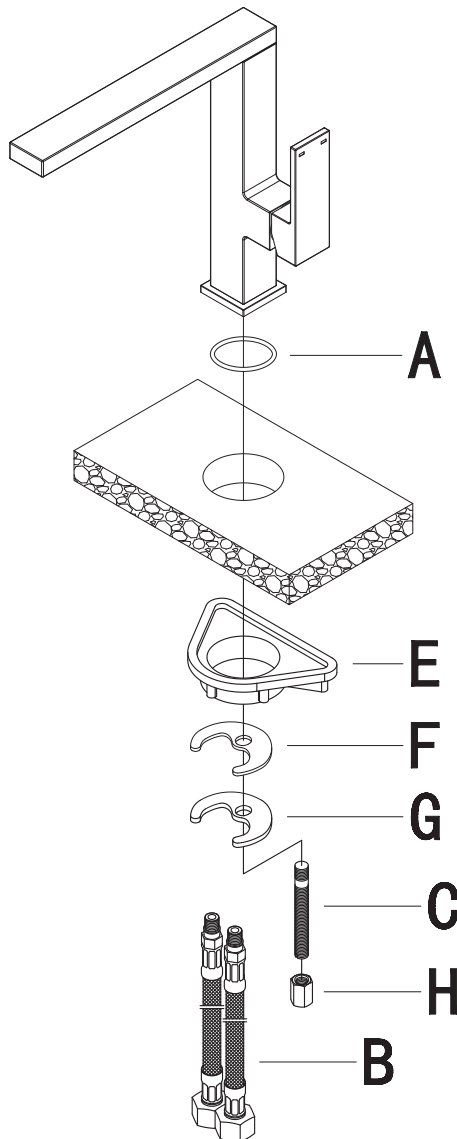

Braided nylon flexible hoses must be inspected every 12 months for warning signs of failure including bulging, rust spots, wear, moisture, snapped threads, kinking, water staining, general corrosion or discolouration. Mixer tails showing any signs of the above mentioned warning signs must be replaced immediately.