

PLUMBERS' INSTALLATION INSTRUCTIONS

Venecia Vitreous China Close Coupled Toilet Suite PLEASE READ CAREFULLY BEFORE INSTALLATION

Preparation for bedding for 'S' trap

Note: Offset connectors with an offset greater than 15mm are not suitable for this pan.

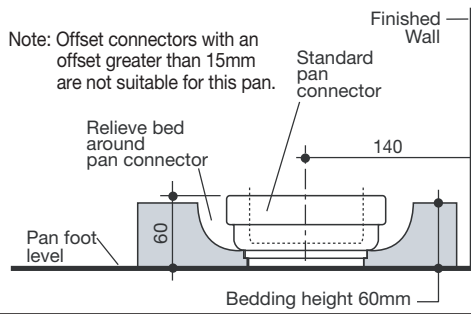

Fig. 1

'P' trap installation

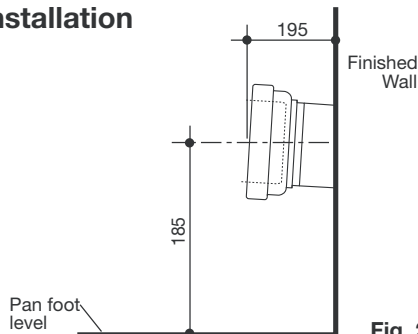

Fig. 2

IMPORTANT: ALL DIMENSIONS ARE TO THE UNDERSIDE FOOT LEVEL OF THE PAN. IT IS IMPORTANT TO MAKE A HEIGHT ALLOWANCE FOR BEDDING.

Bedding Installation

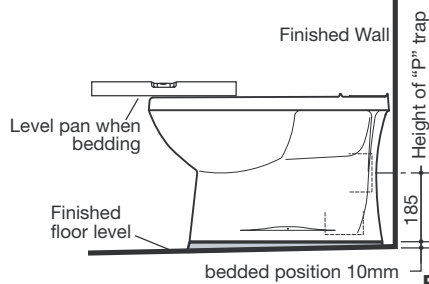

Fig. 3

Screw Fixing Installation

Important: Do not use the pan screw hole as a guide for drilling as this may crack the pan.

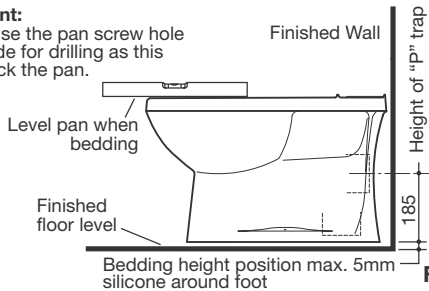

Fig. 4

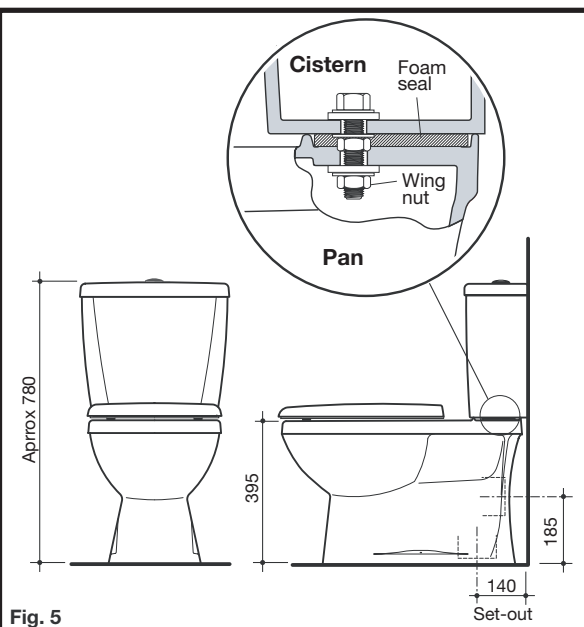

Fig. 5

ROUGHING IN:

The 'S' and 'P'-Trap pan installations are detailed in **Fig 1 & 2**. The recommended set-out for 'S'-Trap installations is 140mm from the finished wall. It is important to position the pan collar 60mm Max. from the foot level of pan as detailed in **Fig. 1**.

PAN FIXING PROCEDURE

Pan bedding:

- 1- Remove an area of tiles which are within the internal area covered by the foot of the pan to expose the sub floor and provide a bondage key for the bedding mixture.
- 2- Ensure that the bedding area is clean and free of building material.
- 3- Prepare bedding sand cement mixture 3:1 to depth of 60mm as detailed in **Fig.1**.
Note: Do not fill the foot of the pan with bedding mix or include lime or fast drying cement into the mix, these may cause cracking in the foot of the pan.
- 4- Position pan and connect with pan connector and level pan into bedding mixture, so that the back of the foot of the pan is approximately 10mm above the finished floor. It is recommended that wedges are used to support the foot of the pan during the positioning.
- 5- Adjust pan position if necessary. Allow bedding mixture to set for at least 24 hours prior to use.

Screw fixing:

- 1- Position pan onto pan connector and locate the cistern onto the pan, checking that the cistern aligns with the finished wall. Adjust pan position if necessary and mark location of pan fixing holes on the floor. Remove the cistern and pan, as detailed in **Fig. 4**.
- 2- Drill two holes in the marked positions on the floor. The hole diameter is dependent on the type of fixing system and floor finish.

IMPORTANT-DO NOT USE THE PAN SCREW HOLES AS A GUIDE FOR DRILLING AS THIS MAY CRACK THE PAN.

- 3- Ensure that the area around the floor is clean and free from building material.
- 4- Run a bead of acetic cured silicone sealant at a height of 8mm approximately fully around the foot of the pan which contacts the floor. Use Wedges around the foot base (if required) so that the **maximum height of silicone sealant is not greater than 5mm on completion on bedding.**
- 5- Reposition pan to pan connector and fix to the floor with suitable corrosion resistant screws. The silicone sealant will bed the pan to the floor. Remove any excess sealant.
- 6- Allow bedding mixture to set for at least 24 hours prior to use.

CISTERN FIXING PROCEDURE

Standard right hand bottom inlet (Internal overflow only) installation

Note: The cistern fixes directly to the pan with a robust base fixing system without the need for wall fixing.

- 1- Securely attach the self-adhesive foam seal around the outlet on the base of cistern, as detailed in **Fig. 5**.
- 2- Locate cistern fixing bolts into pan fixing holes and secure cistern to pan with wing nuts.
- 3- Connect water supply and check operation of cistern.
- 4- If required adjust water level to the water level mark inside the cistern tank with the float adjustment clip.
- 5- Fit lid to check push button operation to complete installation.

The inlet valve can be changed from left to right or vice versa.

All measurements are subject to accepted manufacturing tolerances. To ensure accuracy please check actual product dimensions before drilling for installation. The manufacturer reserves the right to change specifications at any time without giving prior notification. This product should be installed by a qualified plumber. Local authority, Water Board, and Building Regulations may apply to the installation of this product, and you should consult the appropriate bodies on these requirements.