

# Nero

## BIANCA BASIN MIXER



### SPECIFICATION

PRODUCT CODE	YSW3215-01
WELS RATING	5 STAR 5L/MIN
WATERMARK LICENSE	WM-060073
TEMPERATURE RATING	MIN 1°C-MAX 75°C
PRESSURE RATING	MIN 150KPa-MAX 500KPa

### FINISH

	NR321501CH	chrome
	NR321501BRG	brushed rose gold
	NR321501MB	matte black
	NR321501BN	brushed nickel
	NR321501GM	gun metal
	NR321501BG	brushed gold

### MAINTENANCE AND CARE

All surfaces should be cleaned with mild liquid detergent or soap and water.

Do not use cream cleaners or citrus based cleaning products, as they are abrasive.

Use of unsuitable cleaning agents may damage the surface. Any damage caused in this way will not be covered by warranty.

### PACKAGING INCLUDES

- 1x basin mixer
- 2x flexible hose
- 1x threaded pipe
- 1x fixing nut
- 1x steel washer
- 1x rubber washer
- 1x fixing bolt (for fixing nut)
- 1x allen key

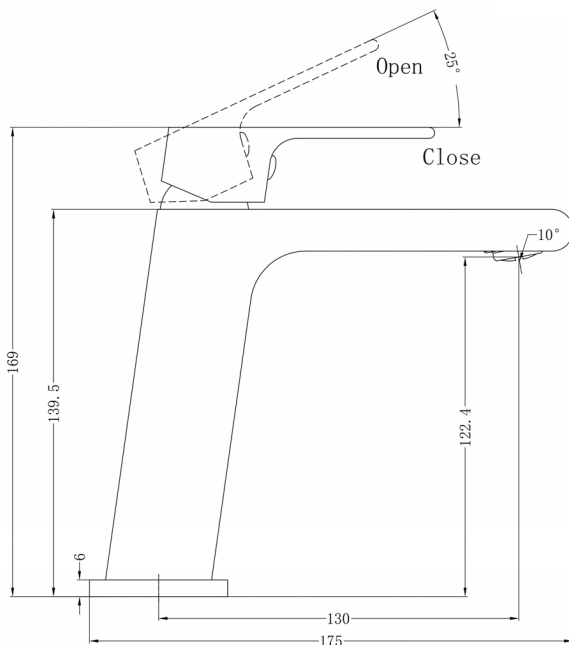

Dimensions are nominal measurements only.



Versions: 2019.11.26

[www.nerotapware.com.au](http://www.nerotapware.com.au)

## INSTALL INSTRUCTION

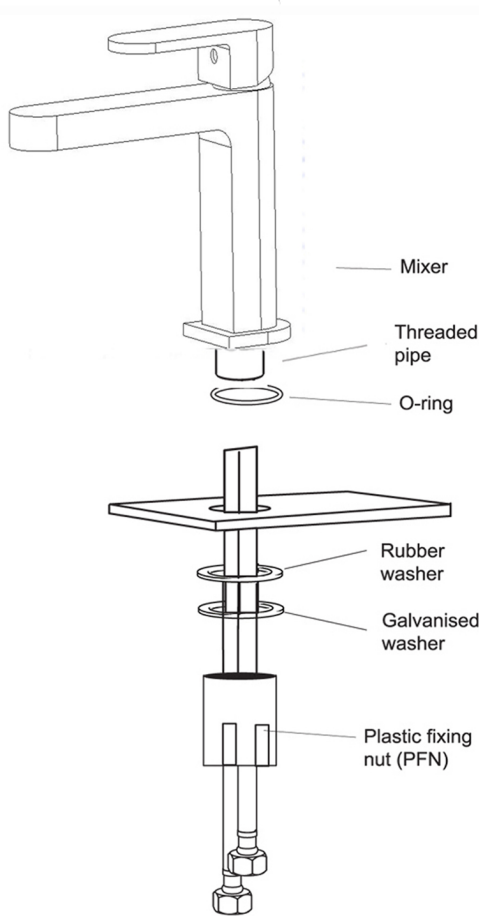

1. Fit the O-ring into the groove in the underside of the mixer body.
2. Screw the flexible hoses into the mixer body, and fully hand tighten.
3. Pass the tail of flexible pipes through the hole on the bench top from above, and place the mixer in position on the bench top. Inspect to see if any alteration to the existing supply pipe work is required. Make any necessary alterations.
4. Tighten the fixing nut to threaded pipes compressing the galvanized washer and rubber washer from the under-side of the counter.
5. Check that the mixer body is correctly positioned, fully tighten the fixing nut screw and fixing bolts firmly..
6. Connect the water supply pipes to the tail of flexible hoses with the hot water and cold water.
7. Test for any leaks.

## EXPLOSIVE VIEW

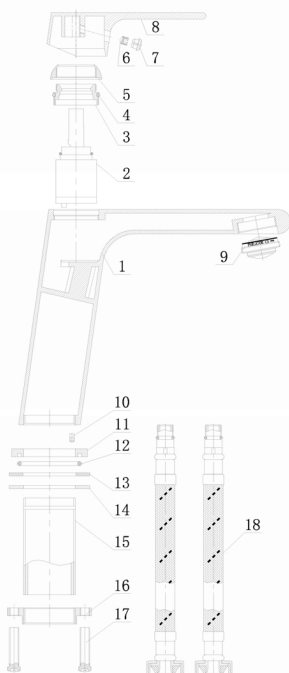

- |                    |                   |
|--------------------|-------------------|
| 1. Body            | 11. Base ring     |
| 2. Cartridge       | 12. O-ring        |
| 3. Retaining nut   | 13. Rubber washer |
| 4. O-ring          | 14. Steel washer  |
| 5. Cartridge cover | 15. Threaded pipe |
| 6. Grub screw      | 16. Fixing nut    |
| 7. Cap             | 17. Fixing bolt   |
| 8. Handle          | 18. Flexible hose |
| 9. Aerator         |                   |
| 10. Locating pin   |                   |