

Madrid

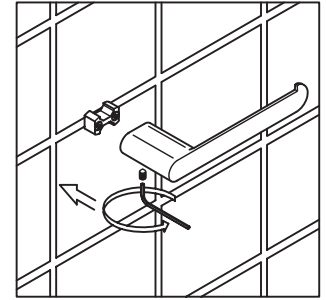

MA824C26CR / MA824C07BN / MA824CC3MB

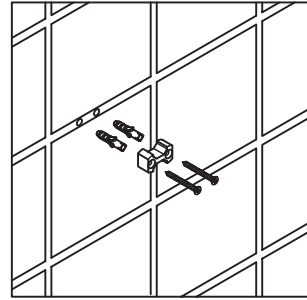
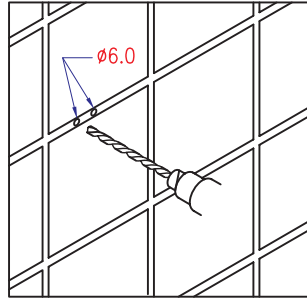
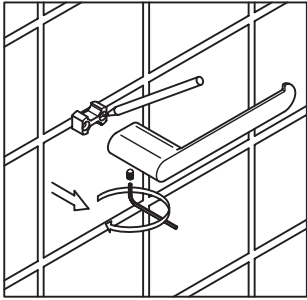
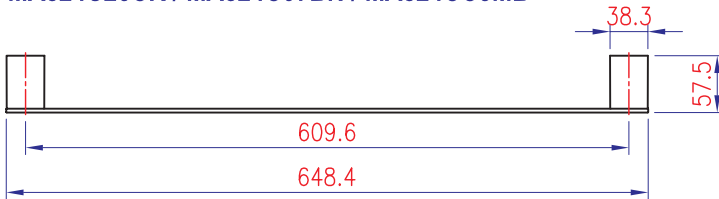

MA860D26CR / MA860D07BN / MA860DC3MB

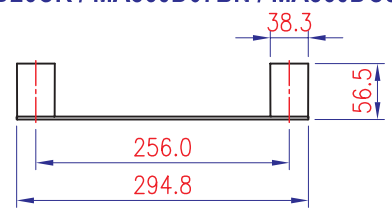

MA824E26CR / MA824E07BN / MA824EC3MB

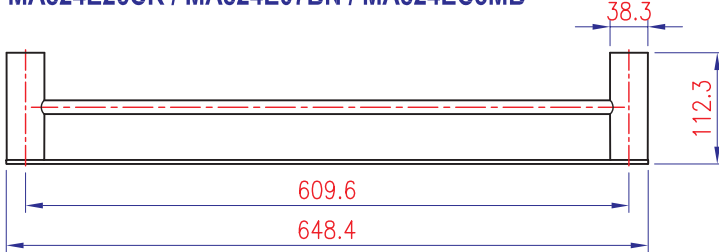

MA854-26CR / MA854-07BN / MA854-C3MB

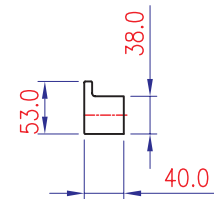

MA830A26CR / MA830A07BN / MA830AC3MB

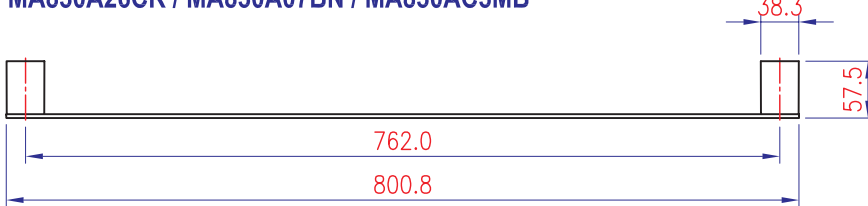

MA855D26CR / MA855D07BN / MA855DC3MB

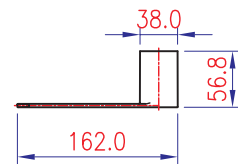

MA830B26CR / MA830B07BN / MA830BC3MB

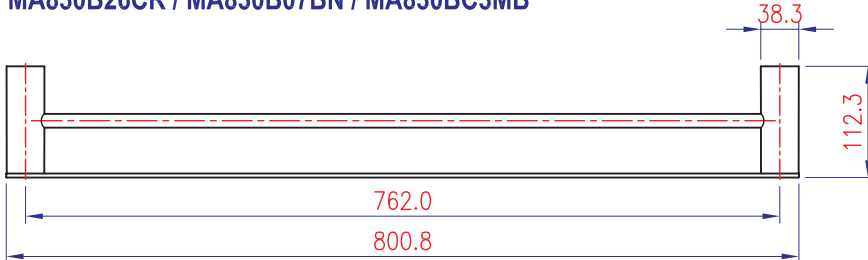

MA859F26CR / MA859F07BN / MA859FC3MB

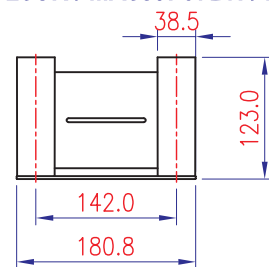

MA891A26CR / MA891A07BN / MA891AC3MB

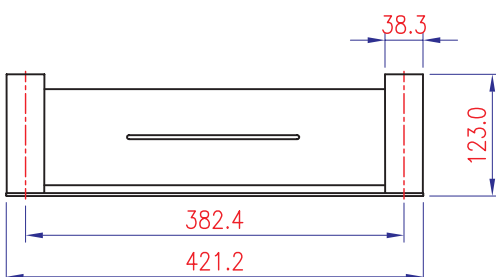

CARE & MAINTENANCE

Clean with a soft cloth and warm soapy water as necessary – rinse and dry after cleaning.

Avoid using abrasive or acid based cleaning products.

WARRANTY

This product is warranted to be free from manufacturing defects for a period of 7 years: 1 year only on labour, when used in a domestic situation.

This warranty does not cover against normal wear and will be voided if the product is misused or not installed in accordance with these instructions.

In the event this product is rendered obsolete and a replacement product is required. Oliveri Solutions Pty Ltd reserves the right to supply a product of equal substitution at their discretion.

Our goods come with guarantees that cannot be excluded under the Australian Consumer Law. You are entitled to a replacement or refund for a major failure and for compensation for any other reasonably foreseeable loss or damage. You are also entitled to have the goods repaired or replaced if the goods fail to be of acceptable quality and the failure does not amount to a major failure.

SERVICE

If the product requires servicing, please contact your installer (preferably the one who installed it).

If the installer is satisfied that the problem is not due to poor installation, contact T2 Services Pty Ltd for assistance on:

Ph: (07) 5596 0738

Fax: (07) 5527 3353

Email: oliveri@t2services.com.au

<https://oliveri.com.au/service-and-warranty>

If a warranty service agent finds that the product is not at fault. T2 Services Pty Ltd reserves the right to pass on any callout fee to the householder.