

Venice

VE112516MB

Matte Black Wall Mixer With Diverter

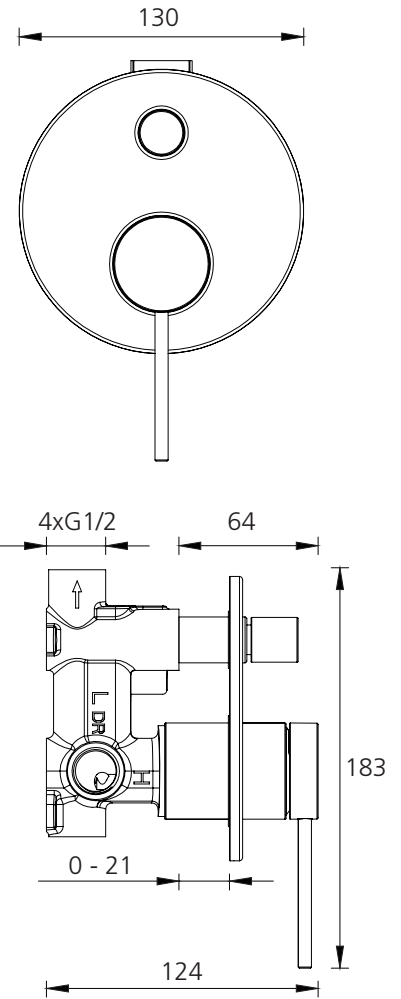

All dimensions in mm

Specifications /

WELS Rating	NA
Temperature rating (min / max)	1°C - 65°C
Pressure rating (min / max)	Min 150 kPa - Max 500 kPa
Finish	Matte black (powder coated)
Materials	Brass body and zinc handle with SUS handle lever
Cartridge size	35mm
Cartridge type	Ceramic disc cartridge
Product weight	1.8kg
Water supply	Mains
Warranty	15 years cartridge; 10 years body; 5 years seals, tails, fittings, aerators; 1 year finish and labour (refer to oliveri.com.au/service-and-warranty-au)
Maintenance and care instructions	All surfaces should be cleaned with mild liquid detergent or soap and water. Do not use cream cleaners or citrus based cleaning products, as they are abrasive. Use of unsuitable cleaning agents may damage the surface. Any damage caused in this way will not be covered by warranty.